

## IP700 / IP1100 TECHNICAL SPECIFICATION

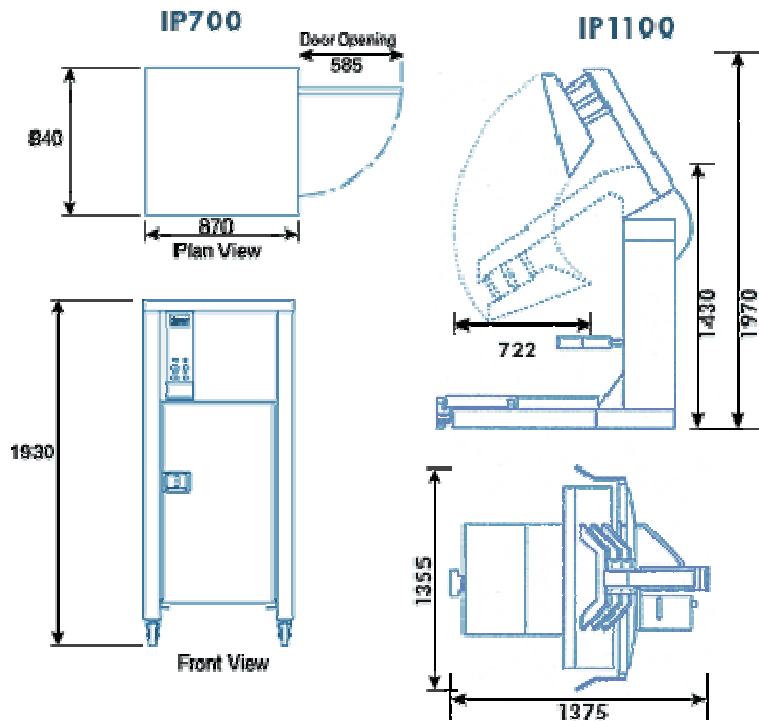

	IP700	IP1100
Average Compacted Weight	40-45kg	-
Compaction Force & Ratio (approx)	1000kgf 5:1	3000kgf 5:1
Cycle Time	17 seconds	-
Motor	0.75kW (1HP)	1.5kW (2HP)
Voltages	240-1-50	230-1-50, 400-3-50
Fuse Ratings	13A	3 phase - 16A
Safety	interlocks on bin & door	safety interlock
Indicator lights	machine run, bin full	machine run
Optional Equipment	deck feet for shipboard installation	-

[print](#) [close](#)

Or download from

<http://www.imco.co.uk/layouts/tech-spec-ip700-ip1100.html>